



## Features

- Compatible with ISO 14230-4
- 2.7 to 6V operating range
- MIL LED output
- Freeze Frame handling
- 10 ms Interbyte time
- Fixed or variable PIDs
- Multiple ECUs handling
- Slow init / fast init selection possible
- Physical and functional addressing
- MODE 1,2,3,4,7,9

## Description

OE91C1110 can simulate ECM ( engine ECU address 0x10 ), TCM ( transmission control ECU address 0x18 ) and ABS ECU address 0x28 simultaneously.

It is compatible with OE90C1100. EOBD modes (1,2,3,4,7,9 ) are implemented. Each ECU has own PID table and variable PID can be changed via potentiometers. The ECM can generate more than 3 DTCs.

The OE91C1110 communicates at 10400 baud with keywords 0x8F and 0xE9 , respond to EOBD addressing (0x33 ) With the slow/fast input , user can select the init type of ECU.

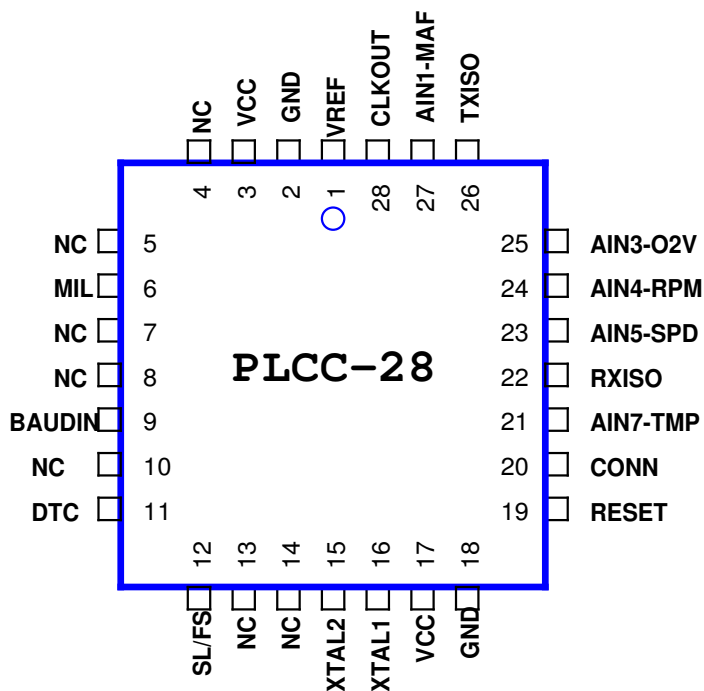

**ÖZEN**  
ELEKTRONIK

**KWP2000  
MULTIPLE ECU  
simulator  
according to  
ISO14230 and  
ISO15031-5**

**OE91C1110**



## Pin description

Pin	Pin Name	Type	Description
1	VREF	I	2.5 V extern ref input for ADC
2	GND		Ground
3	VCC		Supply voltage
4	NC		
5	NC		
6	MIL	O	MIL LED max 5 mA for low current LED
7	NC		
8	NC		
9	BAUDIN *		16 x RS232 Baudrate input clock
10	NC		
11	DTC	I	A low on this input generates 3 DTCs
12	S/F init	I	Input to select slow or fast init
13	NC		
14	NC		
15	XTAL2	I	16 Mhz crystal input
16	XTAL1	I	16 MHz crystal input
17	VCC		Supply voltage
18	GND	I	Ground
19	RESET	I/O	A high level on this pin during 2 machine cycles while the oscillator is running resets the device.
20	LED2	O	LED output to indicate ECU connected to tester
21	AN7	I	Analog canal 7 input
22	RXISO	I	Input ISO receiver
23	AN5	I	Analog canal 5 input
24	AN4	I	Analog canal 4 input
25	AN3	I	Analog canal 3 input
26	TXISO	O	Output ISO K-Line
27	AN1	I	Analog canal 1 input
28	CLKOUT *	O	Clock output for RS232 baud rate in

\* Pins 28 and 9 must be tied together



This simulator chip should be initialized at 5 Baud by receiving 0x33 / or fast init according to ISO14230-4. The successfully connection is indicated by Green LED. Once initialized when no activity is detected on KWP BUS during 5 sec. The connection is interrupted and the green LED goes OFF. Any of not implemented PID gives no response.

## ECM ( engine control modul 0x10 )

### Mode 1

PID	Description	fixed Raw Value	Var. Raw Value
03	Fuel system status	00	-
04	Engine Load	50	
05	ECT		0..255
06	STFT 1	60	
07	LTFT 1	70	
0C	RPM		0..65535
0D	VSS		0..255
0F	IAT	45	
10	Air flow rate of MAF sensor		0...65535
13	Location of O2 sensors	Bank 1 sensor 1	-
14	O2 volt		0..255
1C	OBD Type	EOBD	-
1F	Time since motor start		increments after simulator power on.
21	Distance traveled		increments while MIL LED is active
2F	Fuel level	100	
33	Baro sensor	102	
42	Control voltage	12000	
46	AAT	75	

### Mode 2

when the DTC input is low , P0100 cause a freeze frame storage as follow :

PID	Description	Stored Value
05	Engine coolant temp.	40
0C	Engine RPM	1234
0D	Vehicle speed sensor	67



### **Mode 3**

If DTC button input is low , the MIL LED will be active and the DTCs for , mode 2 , mode 3 and 7 are generated.  
when requesting this MODE the 6 DTCs come from ECM P0100 , P0200 , P0300 , U0100 , B0200 , C0300

### **Mode 4**

delete the DTCs and freeze frame storage datas. MIL LED turns off.

### **Mode 7**

While MIL LED is active , when requesting this MODE the 3 DTCs come from ECM P0107 , P0207 , P0307

### **Mode 9**

Infotypes 1 and 2 are implemented . when requesting VIN Number the response is  
VIN#=OZENELEKTRONIK123



## **TCM ( transmission control modul 0x18 )**

### **Mode 1**

<b>PID</b>	<b>Description</b>	<b>fixed Raw Value</b>	<b>Var. Raw Value</b>
05	Engine coolant temp.		0..255
0C	Engine RPM		0..65535
0D	Speed		0..255
1C	OBD Type	EOBD	-

### **Mode 2**

**Not implemented**

### **Mode 3**

While MIL LED is active , when requesting this MODE the 1 DTCs come from TCM P0101

### **Mode 4**

delete the DTC . MIL LED turns off.

### **Mode 7**

While MIL LED is active , when requesting this MODE the 2 DTCs come from TCM . P0102 , U1600

### **Mode 9**

Not implemented



## **ABS ( ABS modul 0x28 )**

### **Mode 1**

<b>PID</b>	<b>Description</b>	<b>fixed Raw Value</b>	<b>Var. Raw Value</b>
0D	Speed		0..255
1C	OBD Type	EOBD	-

### **Mode 2**

Not implemented

### **Mode 3**

No DTC

### **Mode 4**

No DTC

### **Mode 7**

While MIL LED is active , 1 DTCs come from ABS ( B2245 )

### **Mode 9**

Not implemented



## Application notes

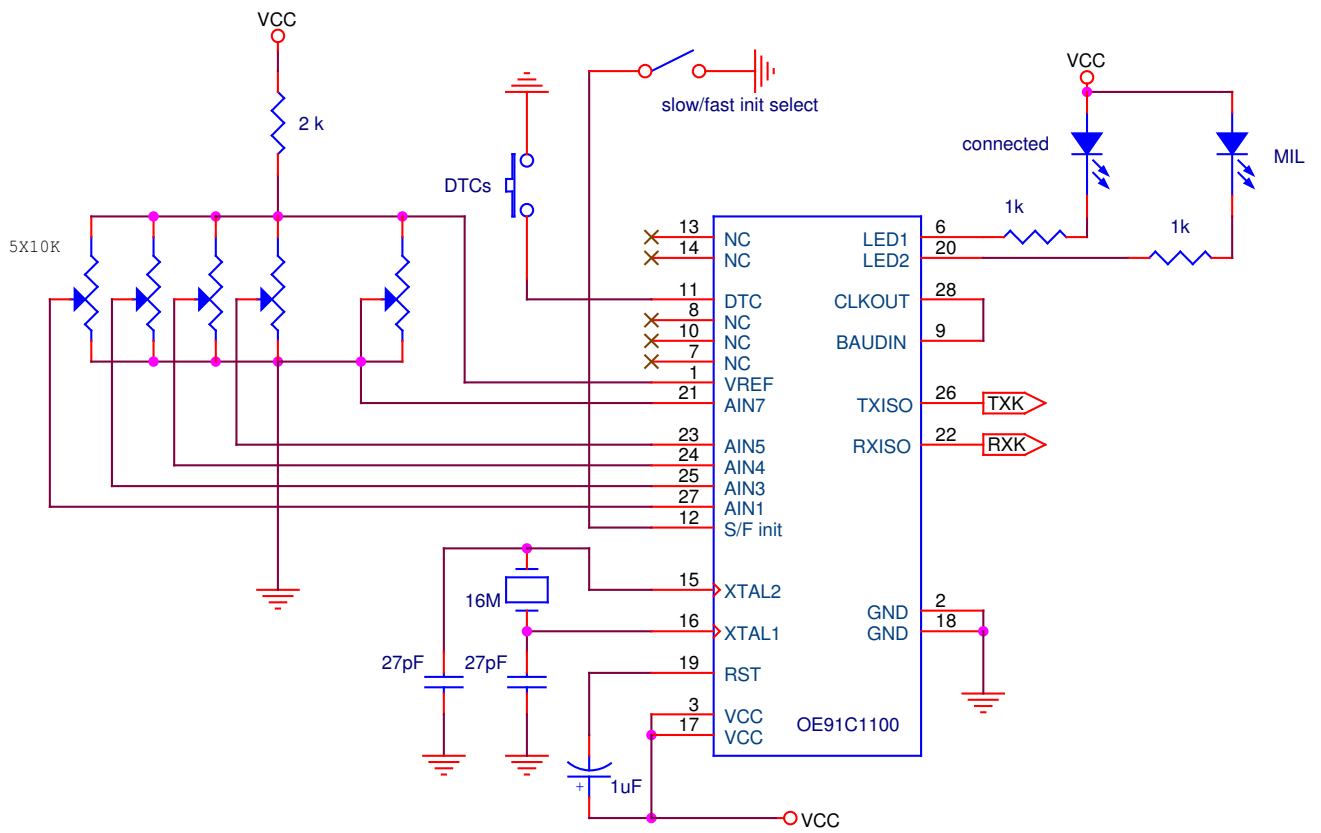

- the both LEDs are low current  $I_f < 5$  mA.
- Don't change the value of crystal.
- Select Fast or slow init with switch

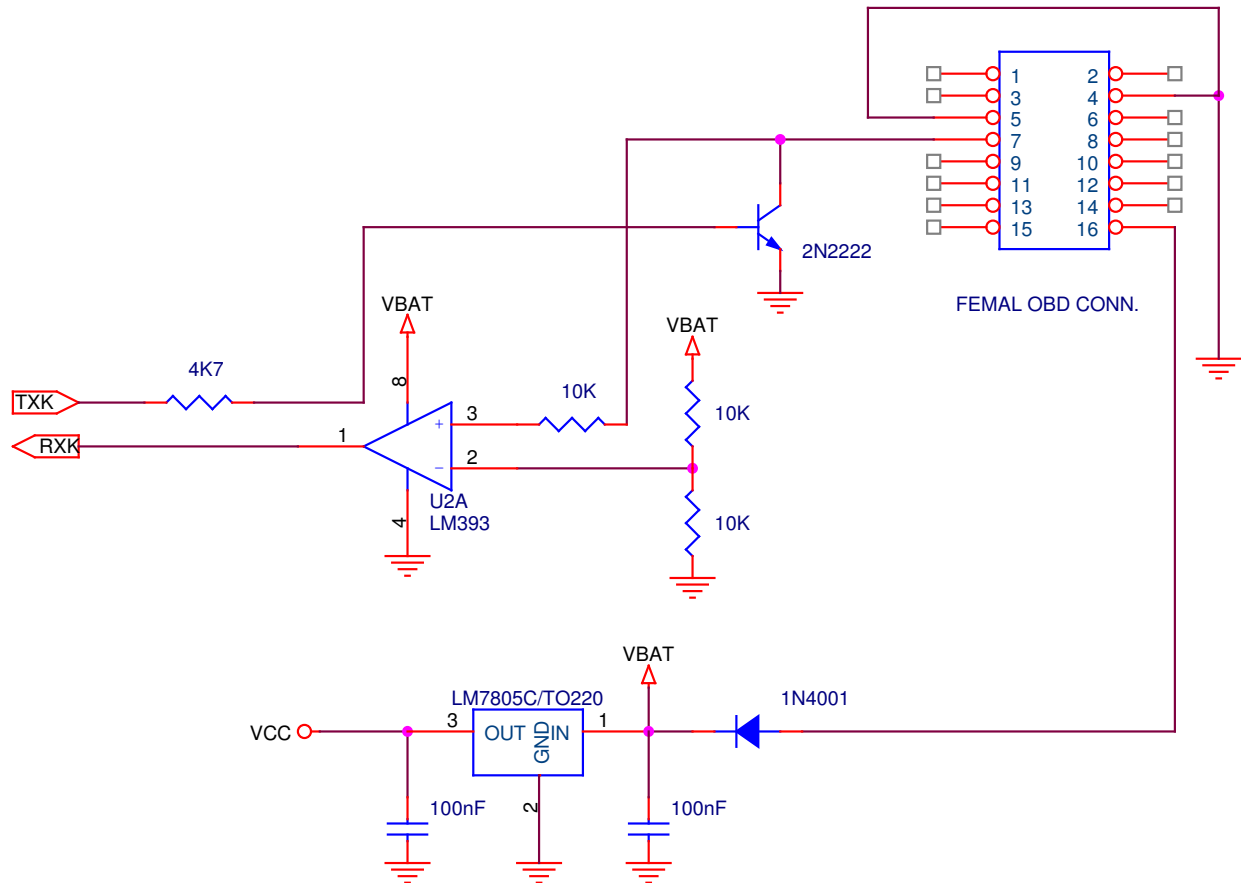

- use a 12 VDC / 500 mA Adapter to power the simulator and the tester.
- A femal OBD connector must be used.