



## Features

- Compatible with J1939 Standard
- 2.7 to 6V operating range
- MIL LED output
- 29 bit / 250 kB CAN BUS communication
- Support some j1979 compliants DMs
- Simulates Truck and CAR ECUs
- ECU source address is 0x00

## Description

OE91C1700 is intended to help to Truck and CAR j1939 protocol programmer. With a few external component , this chip simulate an ECU with 29/250 CAN BUS diagnose output via j1939 protocol. some of J1979 compliant DMs are implemented. Reading live values is realised via 5 pots. When the DTC input is low , one DTC are generated and MIL LED is on till a erase DTC command is sent to simulator.

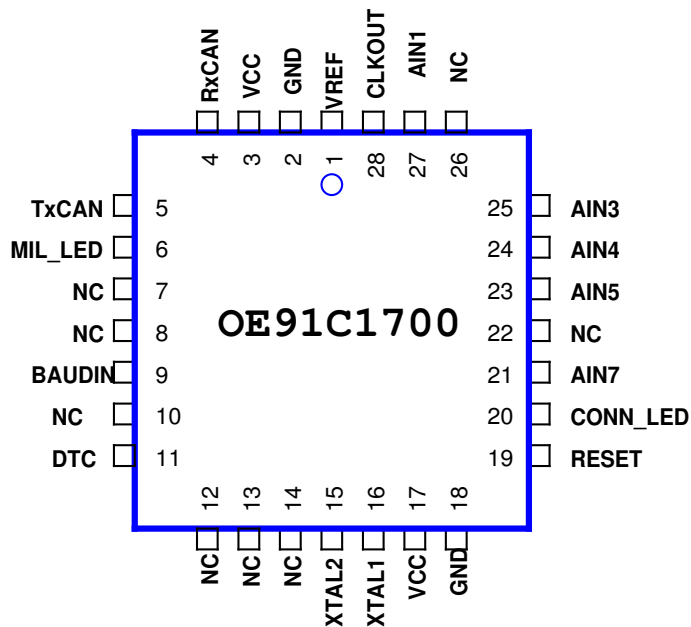

j1939 ECU simulator

OE91C1700



## Pin description

Pin	Pin Name	Type	Description
1	VREF	I	2.5 V extern ref input for ADC
2	GND		Ground
3	VCC		Supply voltage
4	RxCAN	I	J1939 CAN BUS Rx
5	TxCAN	O	J1939 CAN BUS Tx
6	MIL_LED	O	MIL LED max 5 mA for low current LED
7	NC		
8	NC		
9	BAUDIN *		16 x RS232 Baudrate input clock
10	NC		
11	DTC	I	A low on this input generates 1 DTC
12	NC		
13	NC		
14	NC		
15	XTAL2	I	16 Mhz crystal input
16	XTAL1	I	16 MHz crystal input
17	VCC		Supply voltage
18	GND	I	Ground
19	RESET	I/O	A high level on this pin during 2 machine cycles while the oscillator is running resets the device.
20	LED2	O	RUN LED indicating running of simulator
21	AIN7	I	Analog canal 7 input
22	NC		
23	AN5	I	Analog canal 5 input
24	AN4	I	Analog canal 4 input
25	AN3	I	Analog canal 3 input
26	NC		
27	AN1	I	Analog canal 1 input
28	CLKOUT *	O	Clock output for RS232 baud rate in

\* Pins 28 and 9 must be tied together

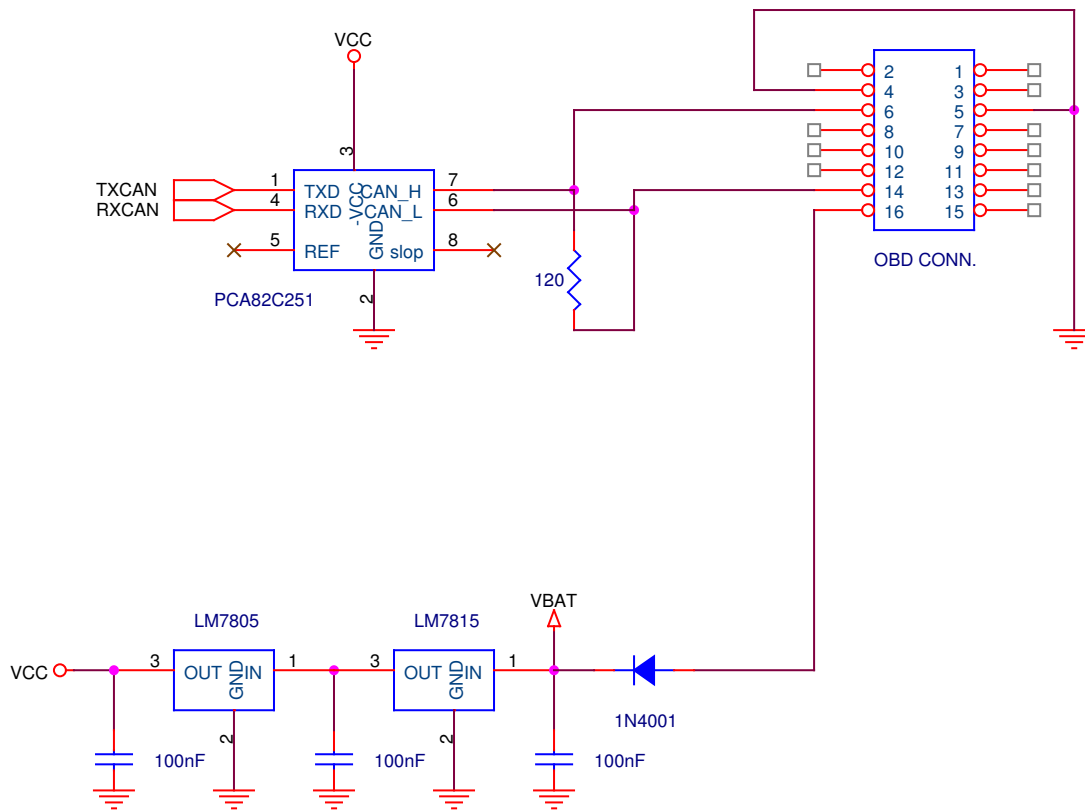
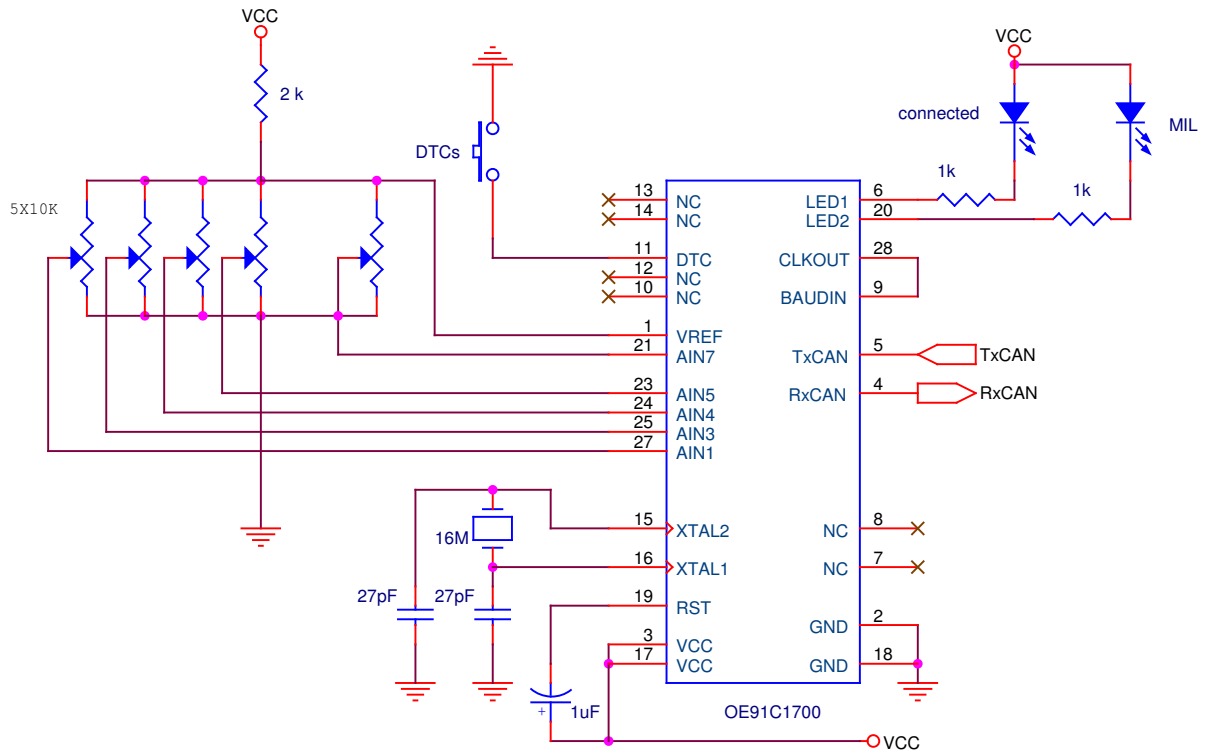



## Value Ranges for Signals

	1 Byte	2 Bytes
Signal Ranges	0 – 0XFA	0 to 0XFAFF
Range reserved for future status info	0XFB – 0XFD	0XFB00 TO 0XFDFF
Defect status	0XFE	0XFE00
Not available	0XFF	0XFF00

## Presentation of switch status ( 2 bits )

Switch off	00
Switch on	01
Defect	10
Not available	11



## Live Data

### **PGN 65262 Engine Temperature 1 - ET1**

Transmission Repetition Rate : 1 s  
Data Length : 8  
Extended Data Page : 0  
Data Page : 0  
PDU Format : 254  
PDU Specific : 238 PGN Supporting Information:  
Default Priority : 6  
Parameter Group Number : 65262 (0xFEEE)

Start Position	Length	Parameter Name	SPN
1	1 byte	Engine Coolant Temperature	110
2	1 byte	Engine Fuel Temperature 1	174
3-4	2 bytes	Engine Oil Temperature 1	175
5-6	2 bytes	Engine Turbocharger Oil Temperature	176
7	1 byte	Engine Intercooler Temperature	52
8	1 byte	Engine Intercooler Thermostat Opening	1134

<b>With ECU simulated parameter</b>	<b>value</b>
Engine Coolant Temperature	-40 to 215 grad <b>variable with pot</b>
Engine Fuel Temperature 1	80 fixed

Another position are all 0xFF ( not yet implemented )



### **PGN 65269 Ambient Conditions – AMB**

Transmission Repetition Rate : 1 s  
Data Length : 8  
Extended Data Page : 0  
Data Page : 0  
PDU Format : 254  
PDU Specific : 245 PGN Supporting Information:  
Default Priority : 6  
Parameter Group Number : 65269 (0xFE5)

Start Position	Length	Parameter Name	SPN
1	1 byte	Barometric Pressure	108
2-3	2 bytes	Cab Interior Temperature	170
4-5	2 bytes	Ambient Air Temperature	171
6	1 byte	Engine Air Inlet Temperature	172
7-8	2 bytes	Road Surface Temperature	79

#### **With ECU simulated parameter**

#### **value**

Barometric Pressure	0xFE ( defective )
Cab Interior Temperature	0xFFFF ( not available )
Ambient Air Temperature	25 grad celcius ( fixed )
Engine Air Inlet Temperature	35 grad celcius ( fixed )
Road Surface Temperature	0xFFFF ( not available )



### **PGN 65257 Fuel Consumption (Liquid) – LFC**

Transmission Repetition Rate : 1 s  
Data Length : 8  
Extended Data Page : 0  
Data Page : 0  
PDU Format : 254  
PDU Specific : 233 PGN Supporting Information:  
Default Priority : 6  
Parameter Group Number : 65257 (0xFEE9)

Start Position	Length	Parameter Name	SPN
1-4	4 bytes	Engine Trip Fuel	182
5-8	4 bytes	Engine Total Fuel Used	250

#### **With ECU simulated parameter**

#### **value**

Engine Trip Fuel 0xFFFFFFFF ( not used )  
Engine Total Fuel Used incremented every 5 ms  
by simulator



### **PGN 61444 Electronic Engine Controller 1 - EEC1**

Transmission Repetition Rate : 100 mS  
Data Length : 8  
Extended Data Page : 0  
Data Page : 0  
PDU Format : 240  
PDU Specific : 4 PGN Supporting Information:  
Default Priority : 3  
Parameter Group Number : 61444 (0xF004)

Start Position	Length	Parameter Name	SPN
1	4 bits	Engine Torque Mode	899
2	1 byte	Driver's Demand Engine - Percent Torque	512
3	1 byte	Actual Engine - Percent Torque	513
4-5	2 bytes	Engine Speed	190
6	1 byte	Source Address of Controlling device	1483
7	4 bits	Engine Starter Mode	1675
8	1 byte	Engine Demand - Percent Torque	2432

**With ECU simulated parameter                      value**

Engine Speed    0..64255 ( **variable with pot** )

**Another data are all 0xFF ( not yet implemented )**









**PGN 65132 Tachograph - TCO1**

Transmission Repetition Rate : 50 ms  
 Data Length : 8  
 Extended Data Page : 0  
 Data Page : 0  
 PDU Format : 254  
 PDU Specific : 108 PGN Supporting Information:  
 Default Priority : 3  
 Parameter Group Number : 65132 (0xFE6C)

Start Position	Length	Parameter Name	SPN
1.1	3 bits	Driver 1 working state	1612
1.4	3 bits	Driver 2 working state	1613
1.7	2 bits	Vehicle motion	1611
2.1	4 bits	Driver 1 Time Related States	1617
2.5	2 bits	Driver card, driver 1	1615
2.7	2 bits	Vehicle Overspeed	1614
3.1	4 bits	Driver 2 Time Related States	1618
3.5	2 bits	Driver card, driver 2	1616
4.1	2 bits	System event	1622
4.3	2 bits	Handling information	1621
4.5	2 bits	Tachograph performance	1620
4.7	2 bits	Direction indicator	1619
5-6	2 bytes	Tachograph output shaft speed	1623
7-8	2 bytes	Tachograph vehicle speed	1624

**With ECU simulated parameter value**

Vehicle Speed 0..64255 ( **variable with pot** )

**Another data are all 0xFF ( not yet implemented )**



## **DM1 transmission**

DM1 contains the lamp status and a list of diagnostic codes and occurrence counts for currently active diagnostic trouble codes. This is all DTCs including those that are emissions related. The currently defined lamps (Malfunction Indicator Lamp, Red Stop Lamp, Amber Warning Lamp, and Protect Lamp) are associated with DTCs. If the transmitting electronic component does not have active DTCs, then the lamp status from that component will indicate that the lamps should be off. However, the component controlling the actual lamp illumination must consider the status from all components that use these lamps before changing the state of the lamps.

Following are the overview and description of various messages in DM1

### **DM1 message overview**

Single packet

(heart beat )

0x18 FE CA 00 1 Sec Transmitted as heart beat only if there are no active faults.

Single packet

(one defect is active)

0x18 FE CA 00 1 Sec Transmitted if there is only one active fault



Transmission Rate : 1 s  
Data Length : Variable  
Extended Data Page : 0  
Data page : 0  
PDU Format : 254  
PDU Specific : 202  
Default Priority : 6  
Parameter Group Number : 65226 (0xFECA)

Byte: 1

bits 8-7 Malfunction Indicator Lamp Status  
bits 6-5 Red Stop Lamp Status  
bits 4-3 Amber Warning Lamp Status  
bits 2-1 Protect Lamp Status

Byte: 2

bits 8-7 Flash Malfunction Indicator Lamp  
bits 6-5 Flash Red Stop Lamp  
bits 4-3 Flash Amber Warning Lamp  
bits 2-1 Flash Protect Lamp

Byte: 3

bits 8-1 SPN, 8 least significant bits of SPN

Byte: 4

bits 8-1 SPN, second byte of SPN (most significant at bit 8)

Byte: 5

bits 8-6 SPN, 3 most significant bits (most significant at bit 8)  
bits 5-1 FMI (most significant at bit 5)

Byte: 6

bit 8 SPN Conversion Method  
bits 7-1 Occurrence Count



## DM1 transmission with no DTC

Byte 1

bits 8-7 = 00  
bits 6-5 = 00  
bits 4-3 = 00  
bits 2-1 = 11

Byte 2

bits 8-7 = 11  
bits 6-5 = 11  
bits 4-3 = 11  
bits 2-1 = 11

Byte 3 to byte 6 = 0 no SPN

Byte 7 = 0

Byte 8 = 0

## DM1 transmission with DTC button pressed

### SPN 1208 is generated

SPN 1208	= 0x4B8	= 000 00000100 10111000 (19 bits)
FMI 3	= 3	= 00011 (5 bits)
OC 10	= 0xA	= 0001010 (7 bits)
CM	= 0	= 0 (1 bit)

Byte 1

bits 8-7 = 01 ( MIL LED on )  
bits 6-5 = 00  
bits 4-3 = 00  
bits 2-1 = 11

Byte 2

bits 8-7 = 11 ( flashing not yet implemented )  
bits 6-5 = 11  
bits 4-3 = 11  
bits 2-1 = 11



DTC																															
Byte 3 8 least significant bits of SPN (bit 8 most significant)								Byte 4 second byte of SPN (bit 8 most significant)								Byte 5 3 most significant bits of SPN and the FMI (bit 8 SPN msb and bit 5 FMI msb)								Byte 6							
SPN																FMI				CM	OC										
8	7	6	5	4	3	2	1	8	7	6	5	4	3	2	1	8	7	6	5	4	3	2	1	8	7	6	5	4	3	2	1
1	0	1	1	1	0	0	0	0	0	0	0	0	1	0	0	0	0	0	0	0	0	1	1	1	0	0	0	1	0	1	0

Byte 7 and byte 8 = 0xFF

### Diagnostic Data Clear/Reset For Active DTCs (DM11)

All of the diagnostic information pertaining to the active diagnostic trouble codes will be erased. Implementers be aware that no positive or negative acknowledgement is sent when the request was sent to the global address.

ECU simulator clears the DTCs and sends a Positive Acknowledgement to this request message.

Transmission Rate : On request using PGN 59904  
 Data length : 0  
 Extended data page : 0  
 Data page : 0  
 PDU Format : 254  
 PDU Specific : 211  
 Default priority : 6  
 Parameter group number: 65235 (0xFED3)



## Diagnostic Readiness 1 (DM5)

Reports the diagnostics information that relates to diagnostic readiness.  
Transmission Rate: On request using PGN 59904

Data Length : Variable  
Extended Data Page : 0  
Data page : 0  
PDU Format : 254  
PDU Specific : 206  
Default Priority : 6  
Parameter Group Number : 65230 (0xFECE)

Byte:

- 1 Active Trouble Codes
- 2 Previously Active Diagnostic Trouble Codes
- 3 OBD Compliance
- 4 Continuously Monitored Systems Support/Status
- 6-5 Non-continuously Monitored Systems Support
- 8-7 Non-continuously Monitored Systems Status

ECU responds with byte 1 = number of DTC and byte 3 = 6 ( EOBD )  
All other parameter are set to 0





## Using PGN 59904

### Parameter Group Name: Request

Definition	: Used to request a Parameter Group.
Transmission repetition rate	: Per user requirements,.
Data length	: 3 bytes
Data page	: 0
PDU Format	: 234
PDU specific field	: Destination Address (global or specific)
Default priority	: 6
Parameter Group Number	: 59904 (0xEA00)

Byte: 1,2,3 Parameter Group Number being requested

Valable Destination Address : 0x00 specific to ECU simulator or 0xFF global



## **Parameter Group Name: Acknowledgment**

**( sent by ECU simulator upon request PGN 59904 for DM11)**

Data length : 8 bytes  
Extended Data Page : 0  
Data Page : 0  
PDU Format : 232  
PDU Specific : Destination address = Global (255)  
Default priority : 6  
Parameter Group Number : 59392 (0xE800)

### Byte

- 1 Control byte = 0, Positive Acknowledgment (ACK)
- 2 Group Function Value (If applicable)
- 3-4 Reserved for assignment by SAE, these bytes should be filled with FF
- 5 Address Acknowledged
- 6 Parameter Group Number of requested information (8 LSB of parameter group number, bit 8 most significant)
- 7 Parameter Group Number of requested information (2nd byte of parameter group number, bit 8 most significant)
- 8 Parameter Group Number of requested information (8 MSBs of parameter group number, bit 8 most significant)

At request for not implemented DMs , simulator sends a NACK setting the control byte to 1. An Acknowledgment message is sent always to global address. Byte 5 in this response is originator source address. Group Function value is set to 0xFF.